

TK32H-M

DIGITAL PODIUM





- 1 - 18" Microphones
- 2 - Shock Mount
- 3 - Power 220V AC
- 4 - RJ45
- 5 - USB
- 6 - Cable Retractor
- 7 - Clock & Timer
- 8 - PC On/Off
- 9 - 22" Multi Touch Screen
- 10 - Height Adjustment
- 11 - Creapen Annotation Software
- 12 - Sliding Top Platform
- 13 - Automatic Screen Angle



You can automatically adjust the height of the podium based on the height of the speaker with the TK32H-M, whose fundamental difference from the TK32H-M model product is the height adjustment motor found in the housing, and you can do this without the speaker noticing with the optional remote.

You can capture the ideal image angle that will automatically adjust the angle of the multitouch speaker screen. You can also safely preserve the sliding cover by locking it when not in use

TK32H-M

	TK32H	TK32H-M
Multi touch speaker screen	22"	22"
Front screen - with Embedded Signage Media Player	32"	32"
Player PC : Intel 4,10 GHz CPU, 120 GB SSD Windows 10 Pro	✓	✓
Switcher & Scakar (HDMI & TYPE-C)	✓	✓
Electrical Lifting Column for Height Adjustment	✗	✓
Electrical Lifting Column for Speaker Screen Angle Adjustment	✓	✓
Microphone	✓	✓
Stereo Amplifier	Optional	Optional
Speakers	Optional	Optional

Speaker Screen

■ 22" iiyama



22" 10 point touch monitor with edge-to-edge glass and AMVA panel

With its Full HD (1920x1080) resolution and accurate Projective Capacitive 10 point touch technology, the ProLite T22 delivers seamless and accurate touch response.

The AMVA panel technology guarantees high performance with excellent colour reproduction and high contrast, making it an excellent choice for a vast array of demanding interactive applications.

Touch Technology

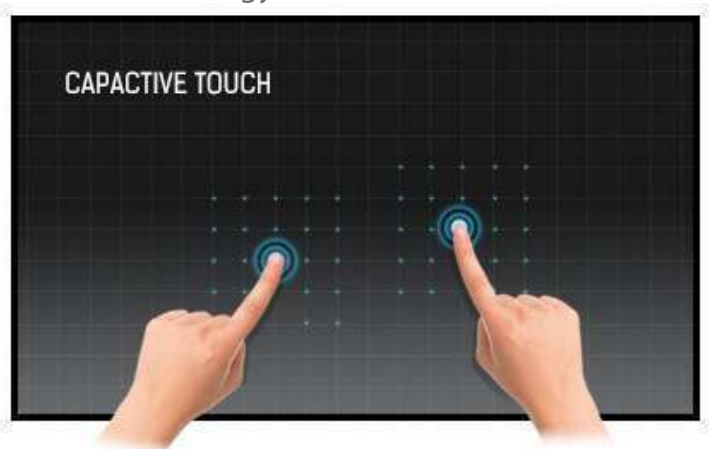

This technology uses a sensor-grid of micro-fine wires integrated into the glass that covers the screen. Touch is detected because electrical characteristics of the sensor grid change when human finger is placed on the glass. Thanks to the glass overlay this technology is highly durable, and the touch function remains unaffected even if the glass is scratched.

It offers perfect picture performance and will work with human finger (also latex gloved) and stylus-pen.

Specifications	
Diagonal	21.5"; 55cm
Aspect Ratio	16 : 9
Panel Amva	LED
Native Resolution	Full HD 1080p, 1920 x 1080 (2.1 megapixel)
Brightness	250 cd/m ² typical
Brightness	215 cd/m ² with touch panel
Advanced Contrast	12 000 000 : 1 ACR
Static Contrast	3 000 : 1 with touch panel
Response Time	8 ms
Viewing Zone	horizontal/vertical: 178°/ 178°; right/left: 89°/ 89°; up/down: 89°/ 89°
Display Colour	16.7 million
Blue Light Reducer	yes
Touch Technology	projective capacitive
Touch Points	10
Glass Hardness	7H minimum
Light Transmittance	85%
Display Area	H X W 268.1 x 476.6 mm; 10.6" x 18.8 "
Pixel Pitch	H X V 0.248 x 0.248 mm
Horizontal Sync	30 - 80 KHz
Vertical Sync	56 - 75 Hz
Synchronization	Separate Sync
INTERFACES / CONNECTORS / CONTROLLERS	
Analog Input Connector	VGA
Digital Input Connector	DVI, HDMI
USB HUB	UP 1 x USB 3.0 / DOWN 4 x USB 3.0
Controls	USB (touch), USB 3.0

■ Front Screen

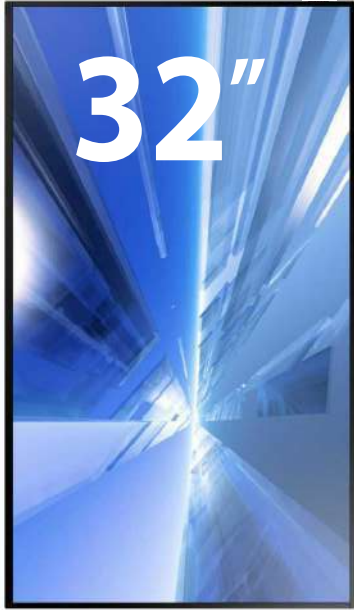

Conveniently and simply manage a rich array of content with an advanced platform

The displays offer durable and extended 24/7 usage to ensure that your business messages are conveyed whenever and wherever they are most impactful.

And, with high 400 nit brightness and crystal clear image quality, your on the podium information are sure to captivate viewers. The unique Picture Quality Enhancer function optimizes the color, detail, contrast and color temperature for your environment with rich color and detailed textures. Viewing is maximized by eliminating factors that can interrupt visibility from light reflection, and reducing glare and haze to only 2%. Plus, connectivity options are enhanced with two HDMI ports for easier enriched content display.

- Durable and extended 24/7 usage for continuous high performance with clear visibility
- All-in-one display solution with embedded media player, no need for external media players
- Simplified content management with built-in Wifi and an easy-to-use mobile application



Integrated Signage Media Player



Built in Wi-Fi

Connect the screen to the CMS wirelessly via the integrated Wi-Fi, ethernet or by LAN

Specifications	
Diagonal Size	32"
Type	60Hz D-LED BLU
Resolution	1920*1080 (Full HD)
Pixel Pitch(mm)	0.12125(H) x 0.36375(V)
Active Display Area(mm)	698.4(H) x 392.85(V)
Brightness(Typ.)	400 nit
Contrast Ratio	5000:1
Viewing Angle(H/V)	178:178
Response Time(G-to-G)	8ms
Display Colors	10bit Dithering - 1.07Billion
Color Gamut	0.72
Operation Hour	24/7
Haze	2%
Dynamic C/R	50,000:1
H-Scanning Frequency	30 ~ 81kHz
V-Scanning Frequency	48 ~ 75Hz
Maximum Pixel Frequency	148.5MHz
Speaker Type	Built in Speaker(10W x 1)

Switch & Scaler

■ 3x2 4K HDMI and USB-C Scaled Out Matrix

Front Panel



Rear Panel



This 3x2 matrix switch is designed for a wide range of flexibility when it comes to inputs, outputs, and control. The two most common video input interfaces (HDMI, USB-C) are included along with a pair of HDMI outputs and a single analog audio breakout port, providing the ultimate in source compatibility and flexibility.

All inputs and outputs are HDCP 2.2 compliant and provide support for resolutions up to a maximum of 4K@60Hz (4:4:4, 8-bit or 4:2:0, 12-bit HDR). The included USB-C input complies with the USB 3.0 standard and supports audio/video bypass, and device charging, as well as the ability to provide a network connection.

This matrix also includes standard USB 3.0 hub functionality with two host ports (one Type-B and one Type-C), plus two device ports (Type-A) for a flexible KVM configuration.

Features

- HDMI 2.0 and DVI 1.0 compliant
- HDCP 1.x and 2.2 compliant
- 1 USB Type-C and 2 HDMI inputs
- 2 HDMI outputs with independent matrix switching and auto-switch support
- Supports up to 4K UHD (18Gbps, 4K@60Hz 4:4:4, 8-bit) video input and output
- Supports Deep Color input and output up to 12-bit
- Supports 10-bit and 12-bit HDR (High Dynamic Range) input/output
- Supports pass-through of many audio formats including 8 channel LPCM, Bitstream, and HD Bitstream
- HDMI Output A supports 4K to 1080p downscaling
- USB-C port functionality is switchable between a A/V focused mode
- (4K@60Hz) with USB 2.0 data and a mixed media mode with simultaneous A/V (4K@30Hz), USB 3.0, and Ethernet support
- USB-C port provides up to 20V/3A (60W) power to the connected device
- Supports pass-through of 8 channel LPCM, bitstream & HD bitstream audio formats
- Analog audio output source audio can be from output A or B (LPCM 2.0 sources only)
- Integrated USB 3.0 hub with one dedicated Type-B host port and two Type-A device ports
- Supports basic signal event automation (via RS-232, Ethernet, or CEC)
- Controllable via front panel 5" Timer screen

Switch & Scaler

■ Operation Controls and Functions

Front Panel

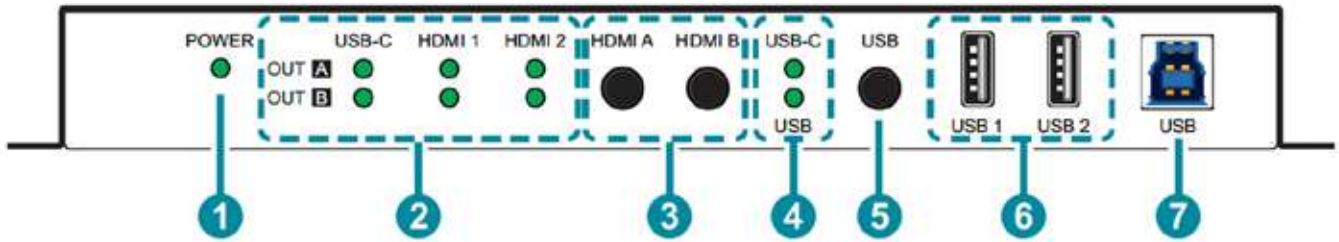

1-POWER LED: This LED will illuminate to indicate the unit is on and receiving power.

2-OUT A & B LEDs: The illuminated LED indicates which source is currently selected for each output.

3-HDMI A & HDMI B Buttons: Press either button to sequentially switch through the available inputs for the associated HDMI output.
EGE-UHD-332C 3x2 4K HDMI and USB-C Scaled Out Matrix

4-USB-C & USB LEDs: The illuminated LED indicates which USB host port is currently active.

5-USB Button: Press this button to select which USB host port is currently active. "USB" selects the USB Type-B port on the front of the unit,

6-USB 1 & 2 Device Ports (Type-A): Connect directly to standard USB devices such as a mouse, keyboard or flash drive to extend their USB functionality to the currently active USB host port.

7-USB Host Port (Type-B): Connect directly to a standard USB host such as a PC or laptop to extend their USB functionality to all currently connected USB devices.

Rear Panel

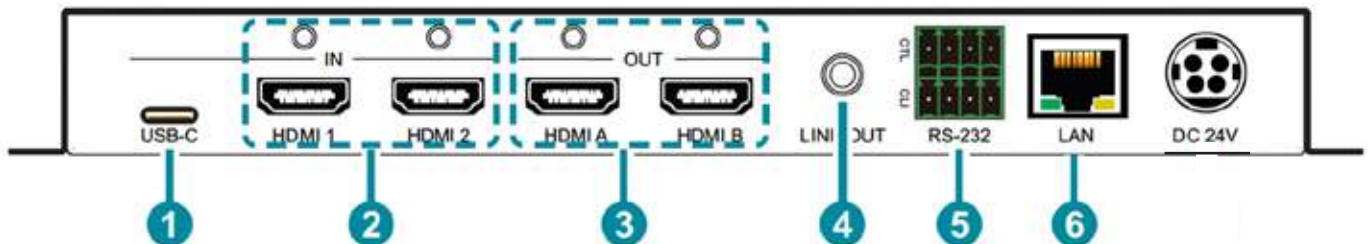

1-USB-C IN Port: Connect to USB Type-C host or video source equipment such as a PC or laptop. When the USB-C port has "Super Speed" support active, this port can support 4K30 A/V, Ethernet, and USB simultaneously. When "Super Speed" is disabled, this port will support full bandwidth 4K60A/V content but USB data functionality will be limited to USB 2.0 levels.

2- HDMI IN 1 & 2 Ports: Connect to HDMI source equipment such as media players, game consoles, or set-top boxes. DVI sources are supported with the use of an HDMI to DVI adapter.

3- HDMI OUT A & B Ports: Connect to HDMI TVs, monitors, or amplifiers for digital video and audio output.

4- LINE OUT Port: Connect to powered speakers, headphones, or an amplifier for analog stereo audio output extracted from the selected HDMI output (LPCM 2.0 sources only).

5- RS-232 CTL 4-pin Terminal Block: Connect to the device you wish to control via a 3-pin adapter cable to receive event automation RS-232 commands from the unit.

6- LAN Port: Connect directly, or through a network switch, to your PC/laptop to control the unit via Telnet/WebGUI and to extend the network across the USB Type-B and Type-C ports.

Switch & Scaler

■ Connection Diagram

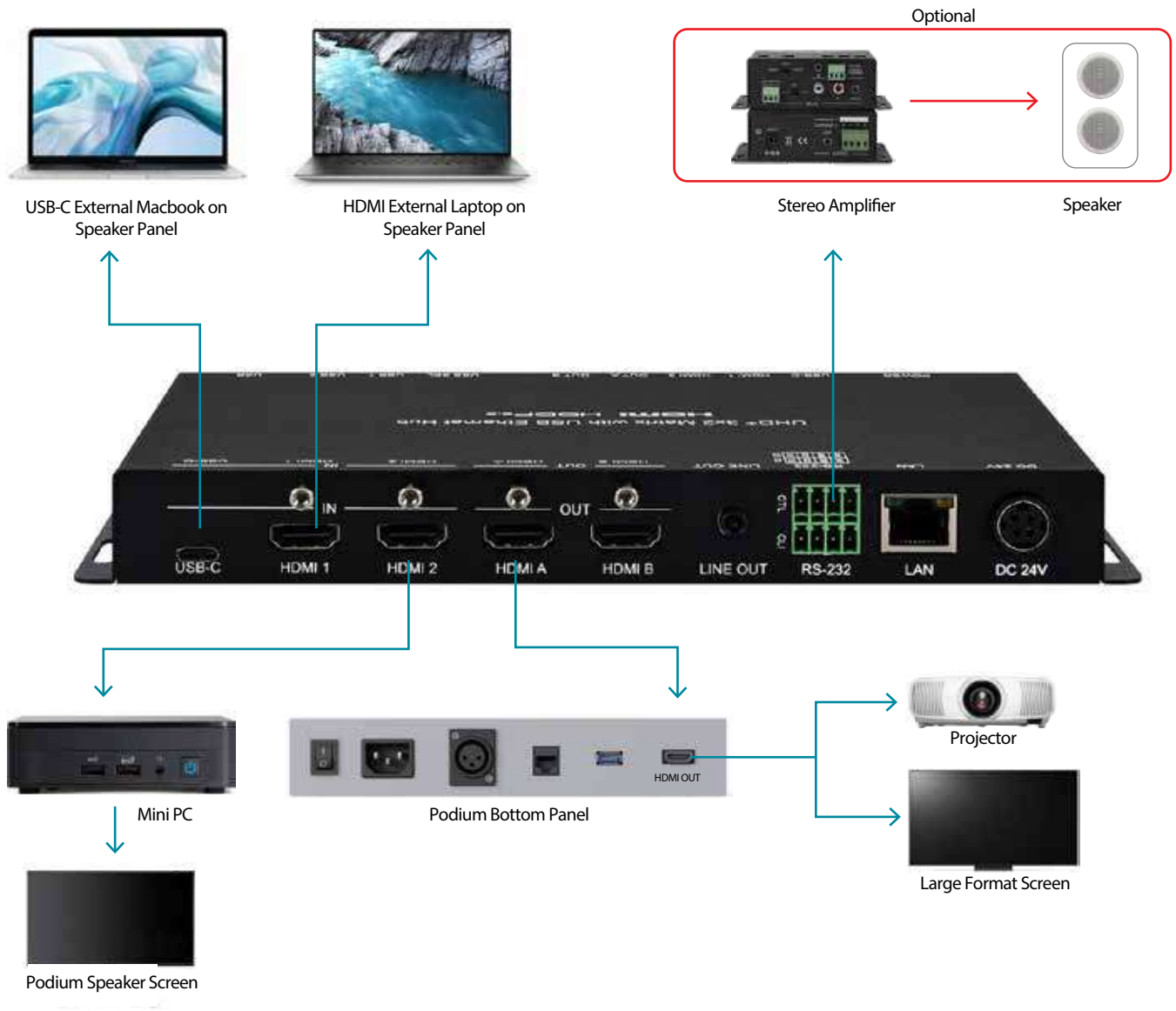

■ Digital Source Selection Diagram

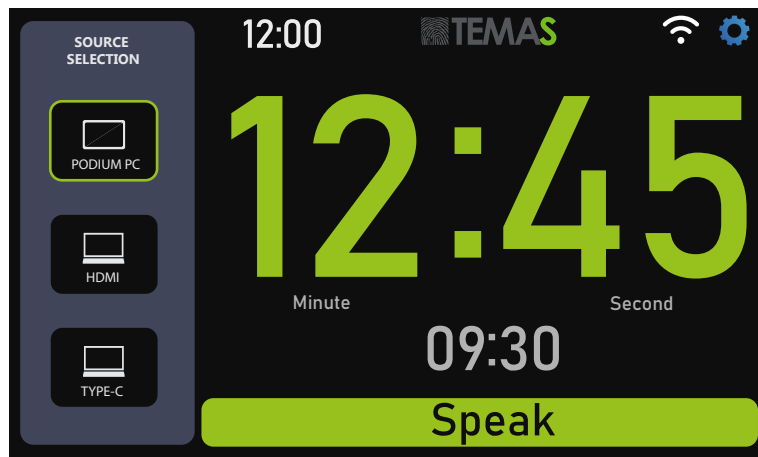



FRONT



BACK

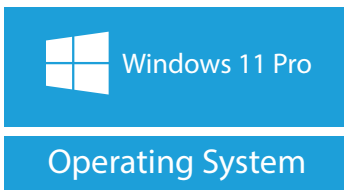

Specifications	
Operating System	Windows 10 Pro
CPU	Intel® Pentium® Gold G6405 Processor 4.1GHz (4M Cache)
Chipset	Intel B560
Graphics	Integrated - Intel HD Graphics
Memory	DRAM MODULE(DDR4)/3200/4G
Storage	128GB M.2 NVMe™ PCIe® 3.0 SSD
Wireless Data Network	Wi-Fi 6, Bluetooth 5.0, 2*2
LAN	10/100/1000 Mbps, Intel LAN
Side(Front) I/O Ports	4 x USB 3.2 Gen2 Type-A (1 w/QC), 1 x USB 3.2 Gen1 Type-C, 2 x Audio Jacks(optional)
Back I/O Ports	1x USB3.2 Gen1 Type-A, 2x USB2.0, 1x RJ45 LAN, 2x Display Port 1.2, 1x configurable ports (HDMI 2.0/VGA/COM/DP/LAN), 1x Kensington lock, 1x DC-in
Power Supply	150W - 19Vdc, 4.74A, 90W Power Adapter
Dimensions (W x D x H)	175 x 175 x 44.2 mm
Weight	1.3KG (HDD included)
Color	Black
Accessories	USB Keyboard & Mouse
Certificates	BSMI/CB/CE/FCC/UL/CCC/Energy Star/C-Tick/WiFi/RF/VCCI

Height Adjustment

■ Linak DL6 Lifting Column



The hallmarks of the DL6 are the 3-stage inline design meaning that the motor is hidden inside the profiles giving the column a very sleek and elegant design easy to integrate in various desk designs. The 3-stage construction ensures a very low built-in dimension meaning that people of all heights can use the desk. The very low noise level ensures pleasant use when driving.

- Max. thrust 1200 N per column
- Max speed: 38 mm/s unloaded
- Bending moment: Max. 150 Nm dynamic
- Low and uniform noise level
- PVC-free column

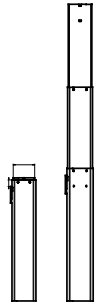

Specifications

Single or 2, 3, 4 parallel drive

Multi-parallel is possible only when in combination with CBD6S

Duty cycle: 10% ~ 2 minutes of continuous use at full load, followed by 18 minutes of pause

Ambient temperature: +5° to +40°C

■ Remote Control



The Hand Control HB10 wireless is designed for control podium remotely The HB10 wireless combines ergonomic design and functionality into a user-friendly hand control with big intuitive buttons and without any annoying cable.

- Hand control controlling 2 channels
- Easily operated by both left and right-handed persons
- Colour on top part is silver (RAL 7035) and the bottom part is a soft black rubber coating
- Simultaneous drive up and down
- Transmitter signal based on 433 MHz or Bluetooth® connection
- Long-life batteries included. Battery lifetime at normal use of 1 minute per day is about 10 years

Microphone

Shure I8 CVGI8S-B Microphone



Designed with dual gooseneck sections for full articulation, the CVGI8 provide scalable, best-in-class performance in a wide variety of locations.

Features

- Cardioid polar pattern with tailored response for speech
- Dual-section gooseneck enables ease of positioning and placement options
- Included Flange Mount and available snap-fit windscreens (ACVG4WS-B – 4 pack)
- With Mute switch/LED,
- Guards against unwanted RF Interference from portable wireless devices gh resistance to intense nearby radio signals
- Superior Shure design and rugged, dependable construction
- Noise by up to 20 dB.

Specifications

Cartridge Type	Electret Condenser	Electret Condenser
Frequency Response		70–16000 Hz
Polar Pattern		Cardioid
Output Impedance		180 Ω
Sensitivity (at 1 kHz , open circuit voltage)		–33 dBV/Pa[1] (22 mV)
Maximum SPL (1 kHz at 1% THD)		120 dB SPL
Signal to Noise Ratio (referenced at 94 dB SPL)		67 dB
Dynamic Range		93 dB
Self Noise (equivalent SPL, A-weighted, typical)		27 dB SPL
Common Mode Rejection (10 Hz to 100 kHz)		45 dB
Preamplifier Output Clipping Level (1% THD)		–7 dBV
Polarity		3
Power Requirements		11–52 V DC[4], 2.0 mA



Shure A400SMXLR Shock Mount

Shure A400SMXLR Shock Mount Socket

A400SMXLR Shock Mount decouples a microphone from the mounting surface and reduces transmission of impact or surface

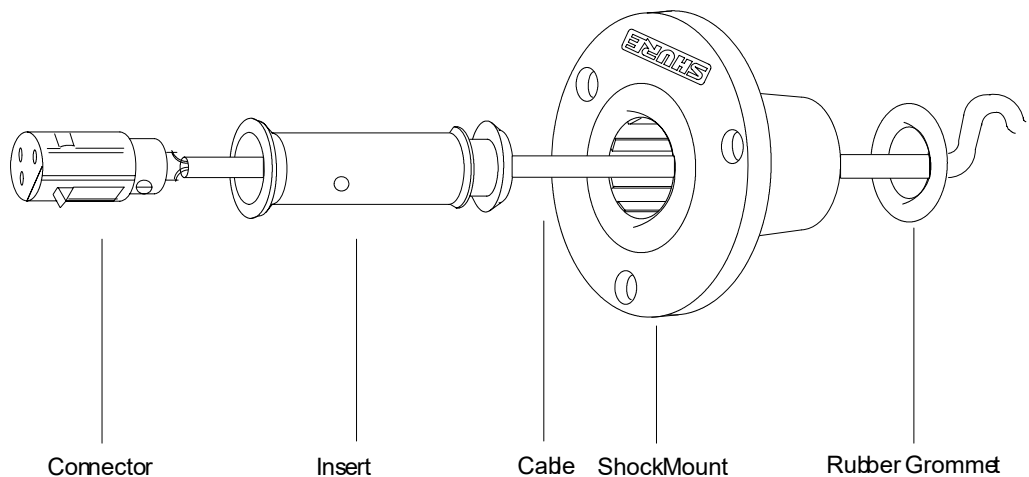

Application

■ 5" Touch screen Timer & Clock

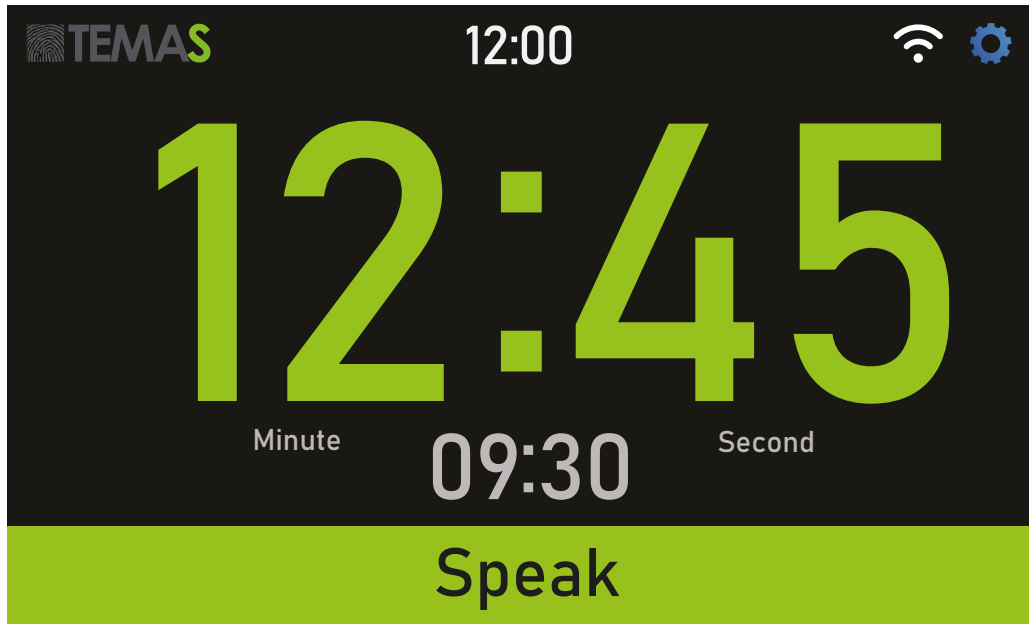

- Speak - Green: 80% of the entire speech
- Sum-up - Orange: The speaker is reminded to end
- End - Red: To remind the speaker to stop talking

Settings

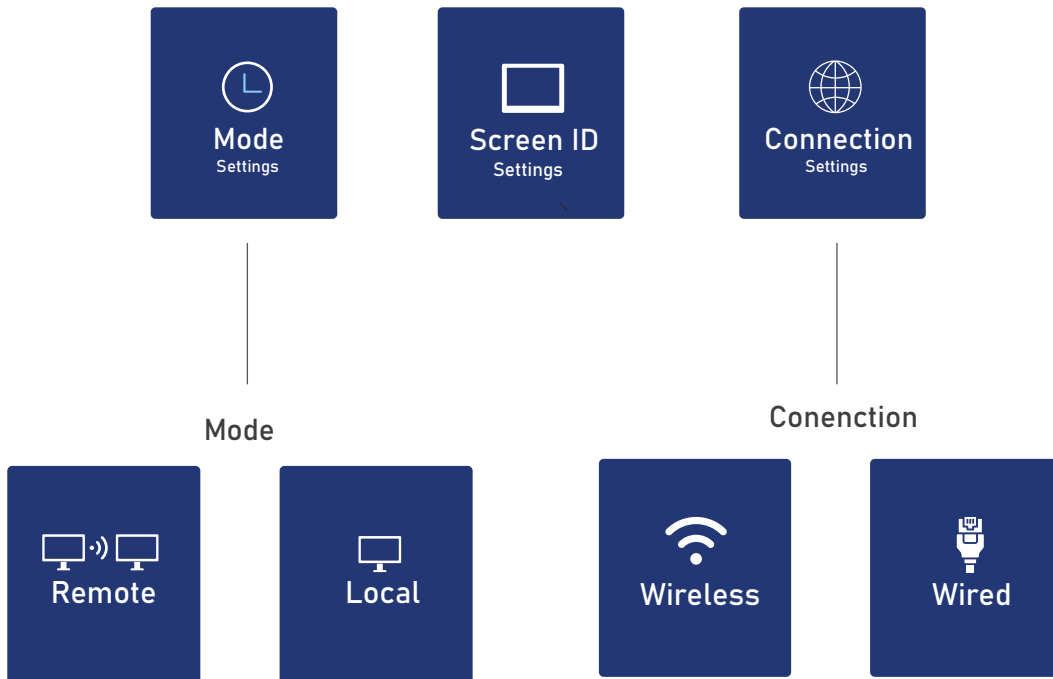

■ HDMI Cable Retractor

Designed for seamless integration with digital podium speaker panels, this innovative solution ensures tidy cable management, quick setup, and a professional look.

1 Cable Management

2 Ease of Use

3 Aesthetics



Cable Management:

Reduced Clutter: Retractors keep cables neatly organized and prevent them from tangling or cluttering the podium area.



Ease of Use:

Convenient Deployment: Retractors allow for easy deployment and retraction of cables. Users can extend the necessary cables when needed and retract them back into the podium when not in use, reducing the risk of damage or tripping hazards.



Enhanced Durability:

Protection from Damage: The retractable mechanism helps protect cables from wear and tear, potential damage, or accidental disconnection. This extends the lifespan of the cables and ensures reliable connections.



Aesthetics:

Sleek Design: A podium with integrated cable retractors has a cleaner and more modern appearance. The sleek design contributes to a professional and organized presentation environment.



User Safety:

Reduced Tripping Hazards: By keeping cables neatly retracted when not in use, the chances of trip hazards are minimized. This is particularly important in spaces where multiple people may be moving around the podium.

Application

■ Creapen Software

Screen Annotation & Screen Recording Solution for Presentations

CreaPen is an extremely simple yet powerful screen annotation and recording software. You can easily write on top of any other application that is currently active on the desktop, even on a running video. You can then save your annotations as an image file or even record the whole session as a video for sharing. It is a useful tool for presenters to communicate and share ideas during a live session, for educators to create effective video tutorials and for salespeople to create impressive video presentations.

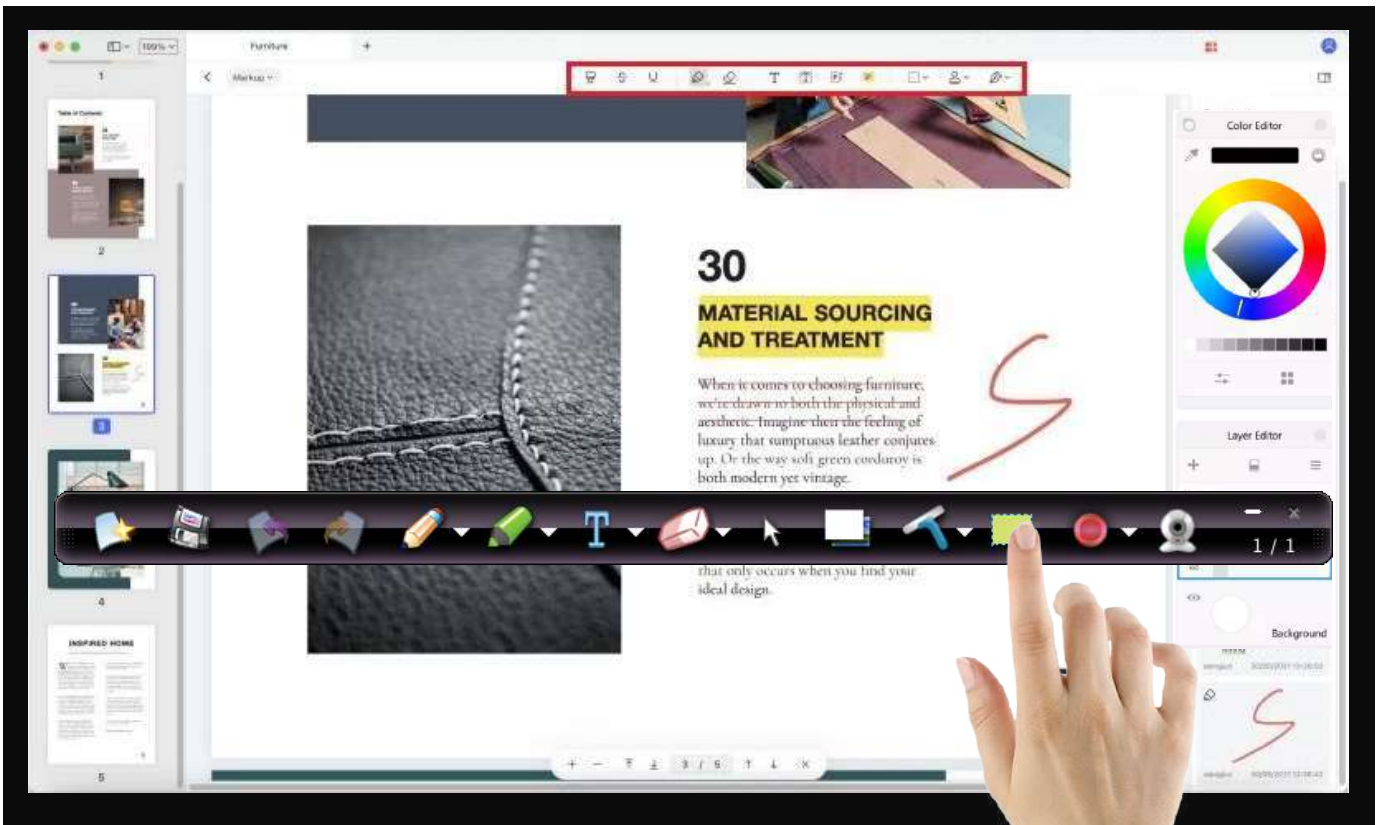
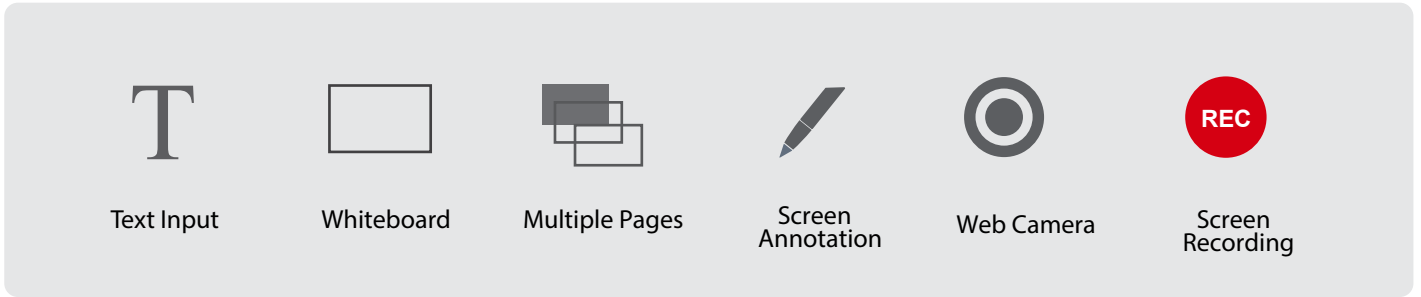
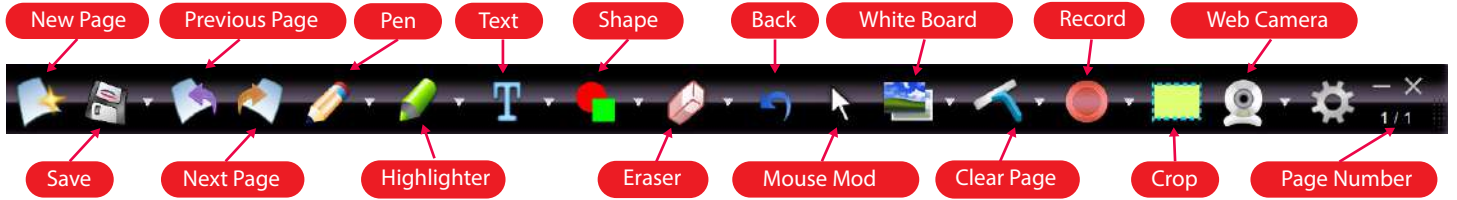

Amplifier

■ Atlona Stereo/Mono Audio Amplifier



- AT-PA100-G2 is a class D amplifier which uses less energy, doesn't require heat syncs or power transformers, making it smaller than a class A/B amplifier
- Stereo, mono, and bridge audio speaker output connections available through captive screw
- Has a variable 3.5mm audio loop out for cascading to another AT-PA100-G2 or connecting to other audio amplifiers
- 3 pin captive screw MIC input can support balanced and unbalanced signals
- Energy efficient standby mode only requires 4Ws of power. AT-PA100-G2 goes into standby mode if an audio signal isn't present
- Control through the panel buttons, an (optional) IR remote, and RS-232
- 3 position input switch: 48V phantom power - best for condenser MICs without battery power
- MIC - Great for Dynamic MICs and battery powered condenser MICs Line - Connect a Wireless
- Volume, Bass, and Treble can be controlled through RS-232, IR, or panel buttons

Specifications	
Rated Output	20 W x 2 40 W x 1 (Bridged Operation)
Gain	32dB
Frequency Range	20Hz to 20KHz
Signal/Noise Ratio	80dB (at max output)
Total Harmonic Distortion	1% (1KHz), 0.3% (20KHz) -- at nominal levels
Input Impedance	Input 1&2: >10KΩ
MIC Input Impedance	48V: 35KΩ MIC: 10KΩ LINE: 75KΩ
Output Impedance	3.5mm Loop Out: 50Ω stereo Speaker out: 4 ~ 8Ω Amplifier
Stereo Channel Separation	75dB from 20Hz to 20KHz
Common Mode Rejection Ratio	70dB from 20Hz to 20KHz
MIC Audio Detection Delay	1ms
Temperature Operating	0°C to 40°C 32°F to 104°F
Temperature Storage	-20°C to 60°C -4°F to 140°F
Temperature Humidity	20 to 90% non-condensing
Power Consumption	40W
Power Idle Consumption	4W
Power Supply	Input: AC100~240V 50/60Hz Output: DC 24V/5A

■ Dual Cone Loudspeaker



The Apart CM4T is the ideal match between size and sound! Just one size bigger than a halogen-spot model (CM3T), this 70 / 100 volt loudspeaker looks great and produces an amazing powerful sound.

Features
outside diameter in mm 135
cutout in mm 108
loudspeaker system dual cone
woofer cone material coated paper
colour white / black / silver
70V transformer power taps in watts 6 - 3 - 1.5 - 0.75
low impedance dynamic power in watts 30
SPL 1W/1m in dB 88
frequency response in Hz 90 - 19K
applicable low impedance yes

MECHANICAL SPECIFICATIONS

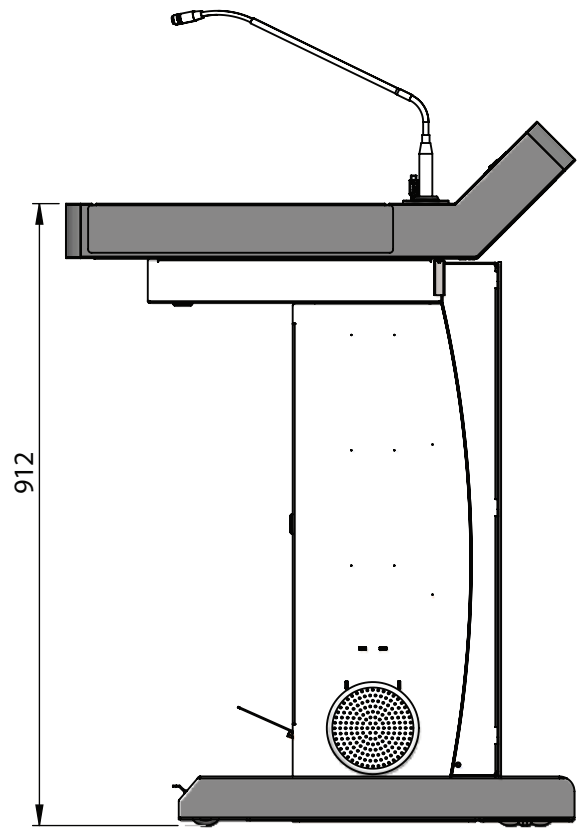
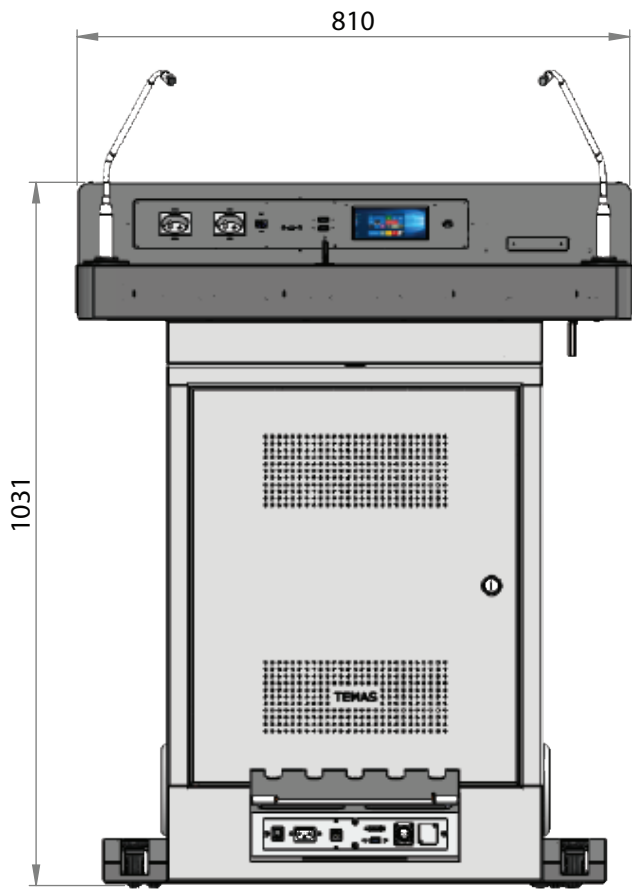

■ Technical specifications

	TK32H	TK32H-M
■ Front Panel	32"	32"
Resolution	1920x1080 FHD	1920x1080 FHD
Brightness	350 cd/m2	350 cd/m2
Aspect Ratio	16:9	16:9
Panel Type	IPS	IPS
Front Panel Player	Digital Signage Media Player	Digital Signage Media Player
■ Lecturer Panel	22"	22"
Screen		
Resolution	1920x1080	1920x1080
Brightness	250 cd/m2	250 cd/m2
Aspect Ratio	16:9	16:9
Number of Touch Point	10 Points Capacitive	10 Points Capacitive
Lecturer Panel PC		
CPU	Intel 4,10 GHz	Intel 4,10 GHz
RAM	4 GB	4 GB
HDD	120 GB SSD	120 GB SSD
Operation System	Windows 11 Pro	Windows 11 Pro
■ Microphone		
Lenght	18"	18"
No of Microphone	1 pcs	1 pcs
Output Connector	3-way XLR(Male)	3-way XLR(Male)
Microphone Type	Cardioid	Cardioid
Frequency Response	50 - 18 kHz	50 - 18 kHz
Power ON Indicator	LED	LED
Power Requirement	Phantom Power (48V)	Phantom Power (48V)
■ Outputs (Bottom of Podium)		
HDMI	Available (Projector Out)	Available (Projector Out)
Ethernet	Network Connection	Network Connection
XLR for Microphone	3-way XLR(Male)	3-way XLR(Male)
USB	USB 2.0 (for internal PC)	USB 2.0 (for internal PC)
■ Electrical Lifting Column for Height Adjustment		
Movement	-	Vertical (Up/Down)
Control	-	By Buttons (Up/Down) and Remote Control
Speed	-	Max speed: 38 mm/s
Lifting Strength	-	700N
Locking System	-	Automatic Locking when engine not working
Engine Type	-	Electrical
■ Mechanical Specs		
Outline Dimesion(mm)Set	810 x 580 x 1615	810 x 580 x 1615
Outlibe Dimension(mm)Package	880 x 940 x 1300	880 x 940 x 1300
Weight(kg)	Set: 105 kg Package: 158 kg	Set: 116 kg Package: 169 kg



Temas Technology Co., Ltd.
Serifali Mahallesi, Kible Sokak, No: 29 34775
Yukarı Dudullu / Umraniye / Istanbul / Turkiye
Tel +90 216 314 54 54 - Fax +90 216 394 44 98
info@temasteknoloji.com.tr - www.temasteknoloji.com.tr