

LCD Monitor Lift

LS15A

User Manual



Read this instruction carefully before using the device



warning

In order to make sure the device is working properly, please follow below instructions:

a. If found any abnormal situation, please cut off the power, pull off the plug and contact your supplier. To avoid any fire accident, DON'T use device in following situations:

- If you found peculiar smell or fog comes from inside of unit.
- If have water or metal parts going to the unit.
- If the lift unit box is broken.
- If the wire is broken inside.

b. As the device is high pressure inside, please DON'T open the unit box at random to avoid fire or electric shock.

c. DON'T put any conducting liquid on top of the device, to avoid electric shock or fire.

d. The device is I type; the power should be connected to ground.

e. The device is suitable for AC 220V 50Hz.

1. Operation instructions

1.1 packing list

NO.	description	remark
1	Monitor lift	1set
2	Power cord	1pc
3	RS-485 cable	1pc

4	User manual	1pc
---	-------------	-----

1.2 Interface on the bottom case (from left to right)



- HDMI in
- VGA in (optional)
- AC 220V input power socket
- USB input, up: USB data, down: USB touch
- RS485 in (1: RS-485 +, 2: RS-485 -, 5: GND)
- RS485 out (use for cluster control)
- Spare: PC SW power on; SA SW signal switch
- ANT Remote control (optional)

1.3 Control Introduction:

RS485 Software Control: 9 holes interface with the computer serial port. 232/485 intermediate bridge converter.



connector(female)



connector(male)

Top panel button:



CONTROL BUTTON. (The Red indicator light is power indicator, if it is red, mean no signal, green is with signal)

Icon	Button
	Stop
	Up
	Down
	Tilting
	Tilting

1.4 Introduction to Manipulation

Display button :



- LED: indicated light, NO SIGNAL: the light is red,
WITH SIGNAL: Light is green.
- : display power on/off
- : Variable Button(-)

-
- ▲ : Variable Button(+)
 - AUTO: Automatic adjustment button and have return function.
 - MENU

2. Characteristics and main parameters

2.1 Structural and functional characteristics

AX-15F motorized monitor lift is using the synchronous belt pulley with a straight line for rising and falling, the tilt driver will as an individual part and the max. angle is 90° (0~90° motorized adjustable) . Stable structure and low noise, using the aluminum frame match with the toughened glass, more elegant. The product uses the desktop embedded design, could hide in the table perfectly.

2.2 Cut out size

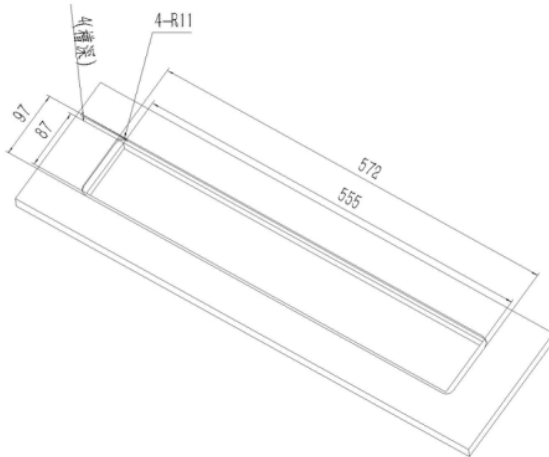

2.3 product size

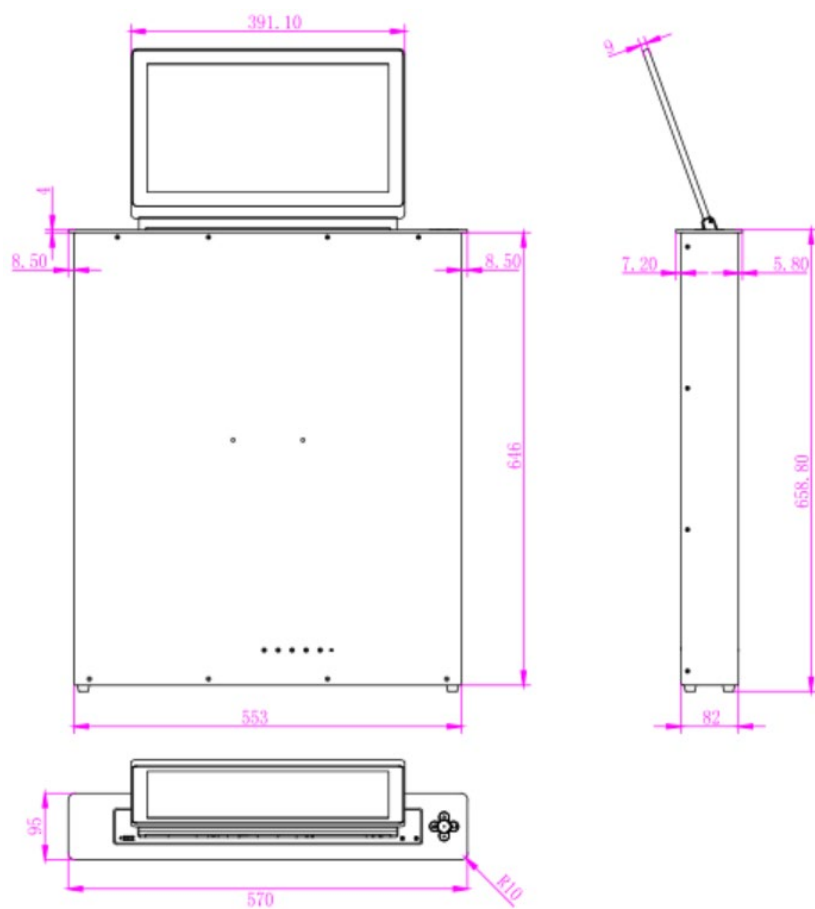

2.4 Technical parameters of lift

No.	Item	Data
1	Voltage	AC 220V 50HZ
2	Power consumption	<50W
3	Single-way running time	18S
4	Tilting	0-90° motorized adjustable

2.5 Technical parameters of display screen

NO.	Item	Data
1	Screen size	15.6 inch
2	Screen type	eDP (2Lanes)
3	Resolution	1920*1080
4	Aspect ratio	16:9
5	Contrast ratio	800:1
6	Brightness	250 cd/m ²
7	Signal type	VGA/HDMI (automatically)
8	View angle	85/85/85/85

3. Installation instructions

3.1 Installation instructions

- Please remove safety screws & remove the foam inside the case before charging (the screws are in the, back, right & left side of cover plate)
- Put the lift into to table cutting hole, and flushing the panel with the table.
- Connect the video signal cable (VGA or HDMI).

- Connect the USB touch line, otherwise the touch screen will not work
- For central control, please connect the RS485.
- Connect the power, when the light is bright, push the button of “up/fall back” to finish the Automatic elevation process. After that, you could push “up/down” button to adjust the angle as you want.

3.2 Central control code

All up	FF AC E1 FF 00 00 DD 01 DC
Stop	FF AC E1 FF 00 00 CD 01 CC
All down	FF AC E1 FF 00 00 ED 01 EC

3.3 Computer App control

- If required, please contact us for RS485 control software “Multifunctional-Lift Control Center V2.0 _win”。
- Prepare a converter of RS232 to RS485 or USB to RS485, and install the driver, connect all the lift which need to be control
- Download and install the software in English version, log in as admin with pass word 88888888, please adjust the langue and the correct COM after access in.
- Operate the assembly according to the app instruction

4. FAQ and Solutions

4.1 Common Faults

NO.	Fault	Reason
-----	-------	--------

	phenomenon	
1	NO display	Check the power on or off? Check the signal, is it interrupted?
2	Character ambiguity	Does it match with the computer resolution? Is the contrast and brightness adjustment correct?
3	Black screen	It would turn off the brightness automatically without signal, Is brightness adjustment minimum? Long press of the "Auto" key may cause shutdown and the indicator to turn red.
4	Invalid touch function	Make sure the USB connection is correct or connect well
5	The indicator is not on	Check if the fuse is damaged. If it is damaged, replace the fuse with 3.15A specification.

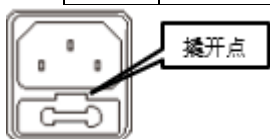

Safety Pipe Location of National Standard Socket

4.2 Common fault judgment method of the control main board

- Test the power socket between "L" and "N" (LT3 terminal of circuit board)
- The regular Resistance is about 1.1K, if there is a big difference

with the value, the PCB must have some problem.

- The indicator light is not lit, the button on panel doesn't work, but central control is working well, maybe because of the poor contact developed due to vibration during shipment.
 - The PCB board is 12V, is abnormal, please check whether the L7812 was damaged
 - The PCB board is 5V, is abnormal, please check whether the L7805 was damaged
 - The upper limit switch belongs to pulse level control, after the pulse, it remains stop. However, the power supply of the display screen needs to keep shade through photoelectric control.
 - Lower limit switch is high levels suspend control, continue to decline low. Thus when the Photoelectric control screen stop to getting down, the display screen needs to keep shade.
-
- Subject to change without prior notice, the current production model shall prevail.
 - For any enquiry, please contact our service center.